

Technical Information PROFIBUS CABLE

PROFIBUS-Interface Pin-layout

The PROFIBUS can be accessed via a 9-pin connector X2 located at the front panel of the VME-PROFI. The interface has separated potentials and a pin-layout as specified in the DIN 19245.

Connector X2	I/O - Signal
Pin 1	n.c.
Pin 2	n.c.
Pin 3	Data B (RxD/TxD-P)
Pin 4	CNTR (Repeater control signal TTL)
Pin 5	GND
Pin 6	Termination-Power
Pin 7	n.c.
Pin 8	Data A (RxD/TxD-N)
Pin 9	n.c.
Connector case	shield

Table 1: Pin-layout PROFIBUS interface

PROFIBUS-Cable

The PROFIBUS standard DIN 19245 Part1 and Part3 permits two types of bus cable (Cable A and Cable B).

Parameter	Cable A PROFIBUS-DP DIN 19245 Part 3 Chap. 6.2 (DMS-Order Code: PROF-KABEL)	Cable B DIN19245 Part 1 / 4.91 Chap. 3.1.2.3
type of cable	Two-conductor shielded twisted pair cable	Two-conductor shielded twisted pair cable
Impedance	135 ... 165 Ω (3 ... 20 MHz)	100 ... 130 Ω (f > 100kHz)
Capacity	< 30 pF/m	< 60 pF/m
Loop resistance	< 110 Ω/km	-
Diameter	> 0,64 mm	> 0,53 mm
	> 0,34 mm ²	> 0,22 mm ²

Table 2: PROFIBUS cable parameter

The maximal bus length depends on the type of cable and the baud rate (see table).

Baud rate kBit/s	9,6	19,2	93,75	187,5	500	1500	3000
Cable A, max. distance in m (without repeater)	1200	1200	1200	1000	400	200	100
Cable B, max. distance in m (without repeater)	1200	1200	1200	600	200	--	--

Table 3: Maximal bus length

The maximal bus length can be extended until approx. 10 km with repeaters. The max. number of repeaters that can be used in a network depends on the type of the repeater and is between 3 and 10.

Technical Information PROFIBUS CABLE

The PROFIBUS is a linear bus from device to device. Only short stubs are possible, see DIN 19245 Part1 and 3. The bus cable can be ordered from DMS with the order code „**PROF-KABEL**“ (= cable type A). The bus cable must be terminated at both ends. We recommend connectors with integrated, switchable termination resistors (order code : „**PROFI-STV**“ or „**PROFI-STVG**“).

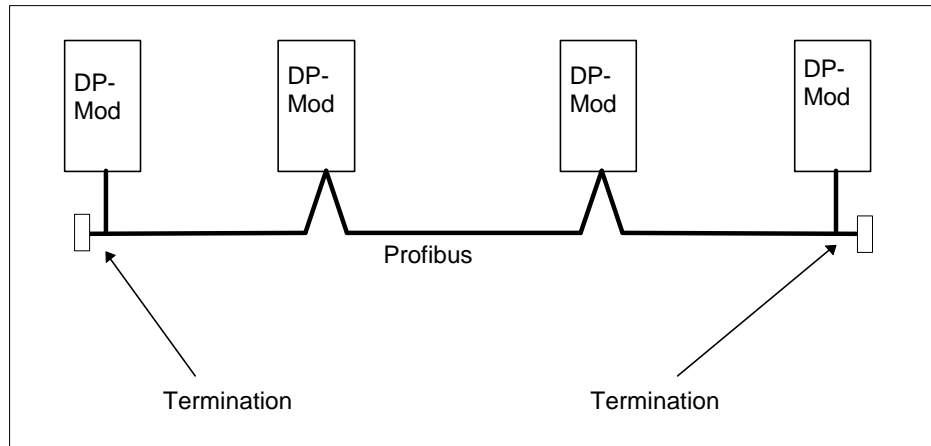

Figure 1: Bus cable with termination

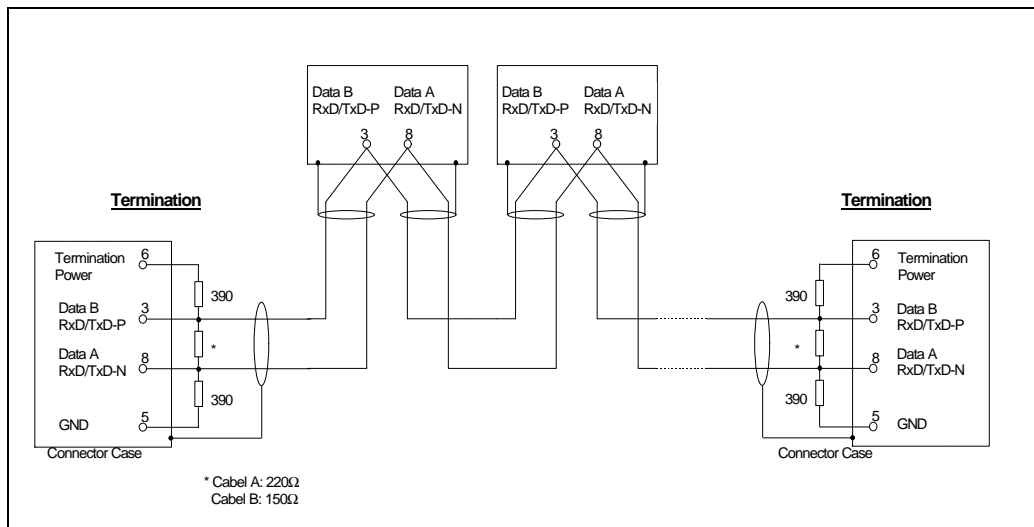

Figure1: PROFIBUS Connection diagram

PROFIBUS connector

DMS offers two types of PROFIBUS connectors. Both connectors are designed to be used together with the cable „**PROF-KABEL**“

Order Code	comment
PROFI-STV	PROFIBUS bus connector plug (9 pol., DSUB) with switching terminators, variable cable outlets (0° / 45° / 90°), plastic case.
PROFI-STVG	PROFIBUS bus connector plug (9 pol., DSUB) with switching terminators, straight type with metal casing. This bus connector is recommended for use with a PCI-40, IPE, or PCU.

Technical Information PROFIBUS CABLE

PROFIBUS Cable example

The following pictures shows, how a PROFIBUS Cable is build with the PROF-KABEL and the PROFI-STV connector.

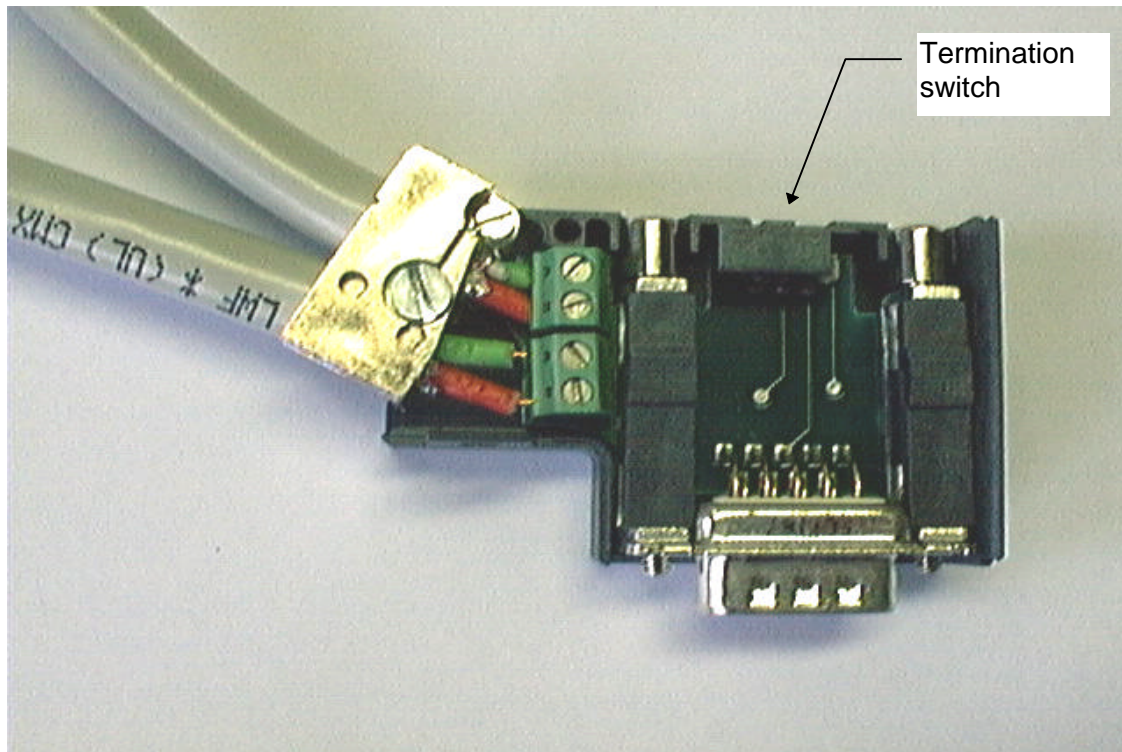

The termination of the first and the last connector must be switched on. All other termination switches are off.

